

MALE END VIEW

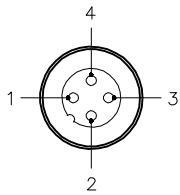

- 1 = BROWN
- 2 = N/C
- 3 = BLUE
- 4 = BLACK



SPECIFICATIONS

|                               |                                  |
|-------------------------------|----------------------------------|
| CONTACT CARRIER MATERIAL      | NYLON OR TPU                     |
| MOLDED HEAD MATERIAL/COLOR    | TPU/YELLOW                       |
| CONTACT MATERIAL/PLATING      | BRASS/GOLD                       |
| COUPLING NUT MATERIAL/PLATING | BRASS/NICKEL                     |
| RATED CURRENT [A]             | 4.0 A                            |
| RATED VOLTAGE [V]             | 250 V                            |
| OUTER JACKET MATERIAL/COLOR   | TPU/GRAY                         |
| CONDUCTOR INSULATION MATERIAL | PVC                              |
| NUMBER OF CONDUCTORS [AWG]    | 3x22 AWG                         |
| TEMPERATURE RANGE             | -40°C to +90°C (-40°F to +194°F) |
| PROTECTION CLASS              | MEETS NEMA 1,3,4,6P AND IEC IP68 |

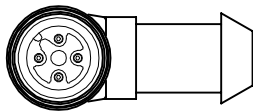
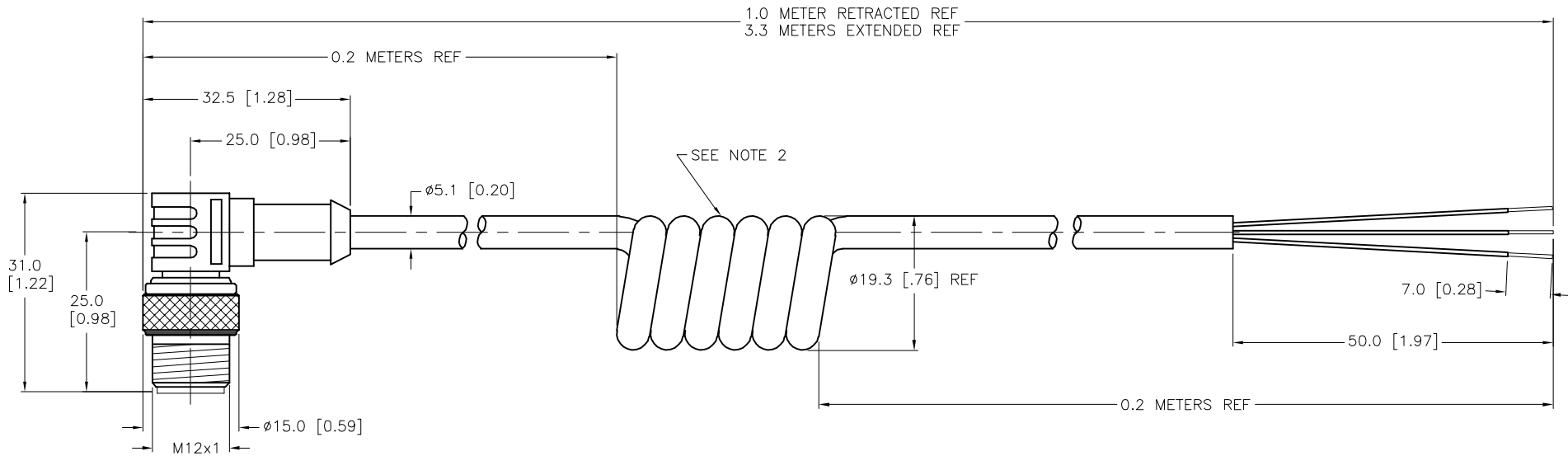

SOURCE DRAWING - FOR REFERENCE ONLY

NOTES:

- 1. "/S90" DESIGNATES THERMOPLASTIC POLYURETHANE (TPU) CABLE JACKET.
- 2. NUMBER OF COILS IS REFERENCE ONLY.

|   |   |  |   |  |                           |                                 |
|---|---|--|---|--|---------------------------|---------------------------------|
| RELATED DOCUMENTS<br>1.<br>2.<br>3.<br>4. | 3RD ANGLE PROJECTION<br>  | THIS DRAWING IS CONFIDENTIAL AND THE PROPERTY OF TURCK INC. USE OF THIS DOCUMENT WITHOUT WRITTEN PERMISSION IS PROHIBITED. |   | 3000 CAMPUS DRIVE<br>MINNEAPOLIS, MN 55441<br>1-800-544-7769<br>(763) 553-7300<br>(763) 553-0708 fax<br>www.turck.us |                           |                                 |
|   |   | DRFT   | CBM   | DATE   | 10/09/00                  | DESCRIPTION<br>WS 4T-3.3/S90-SP |
| MATERIAL<br>SEE SPECIFICATIONS            | ALL DIMENSIONS DISPLAYED ON THIS DRAWING ARE FOR REFERENCE ONLY | APVD   |   | SCALE  | 1=1.0                     |                                 |
| FINISH<br>SEE SPECIFICATIONS              |   | CONTACT TURCK FOR MORE INFORMATION   | UNIT OF MEASUREMENT<br><b>MILLIMETER [ INCH ]</b> |  |                           | IDENTIFICATION NO.<br>U2519-0   |
| I   | UPDATE MALE COUPLING NUT  |  | NF  | 04/20/18   | 56903                     | REV<br>                         |
| REV                                       | DESCRIPTION   | BY   | DATE  | ECO NO.  | DO NOT SCALE THIS DRAWING |                                 |
|   |   |  |   |  | FILE: U2519-0             | SHEET 1 OF 1                    |